

# ATmega328

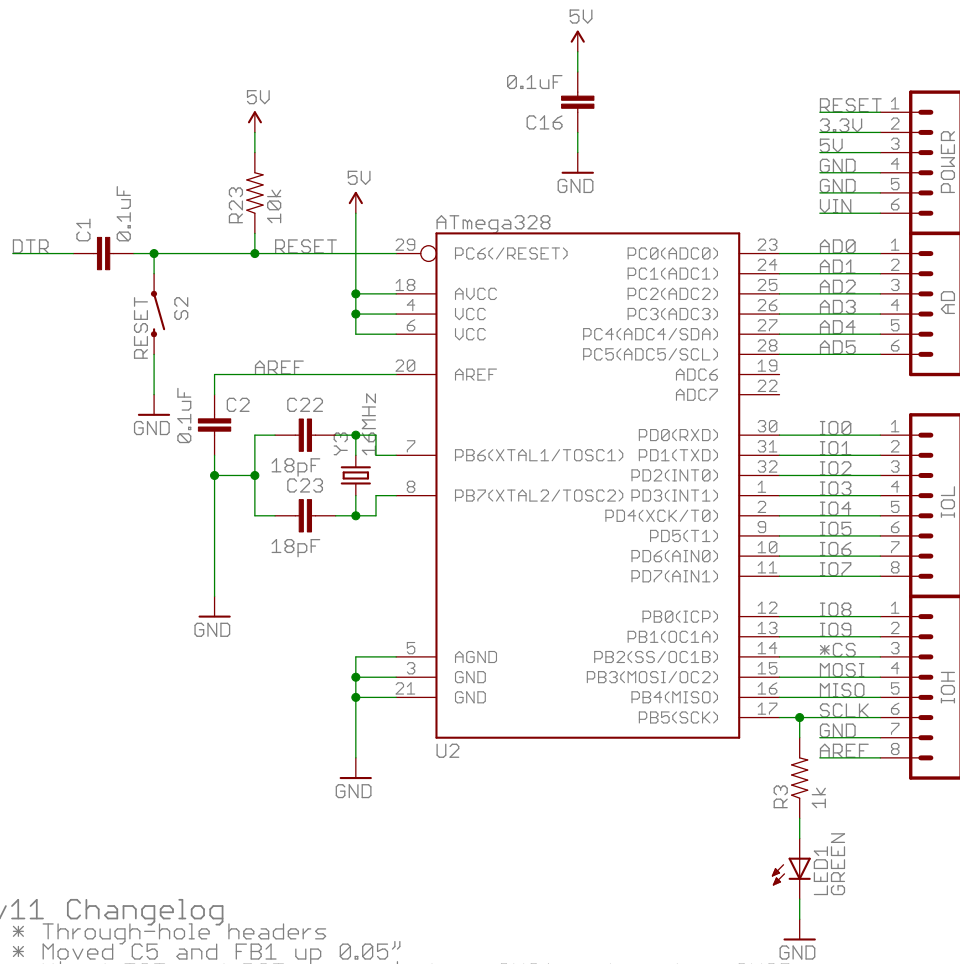

## v11 Changelog

- \* Through-hole headers
- \* Moved C5 and FB1 up 0.05"
- \* Wired TCT and RCT on magjack to 3V3A rather than 3V3D
- \* Changed C18 & C19 to 10uF Tantalum caps, added C20
- \* Added 5V and 3.3V polygons to vregs, thermal vias
- \* Spaced out LEDs for better visibility of labels
- \* Added top-left standoff
- \* Added C21
- \* 16MHz Resonator replaced with 16MHz Crystal



Released under the Creative Commons Attribution-ShareAlike 3.0 License  
<http://creativecommons.org/licenses/by-sa/3.0>  
 Design by: Jim Lindblom

# Voltage Regulation

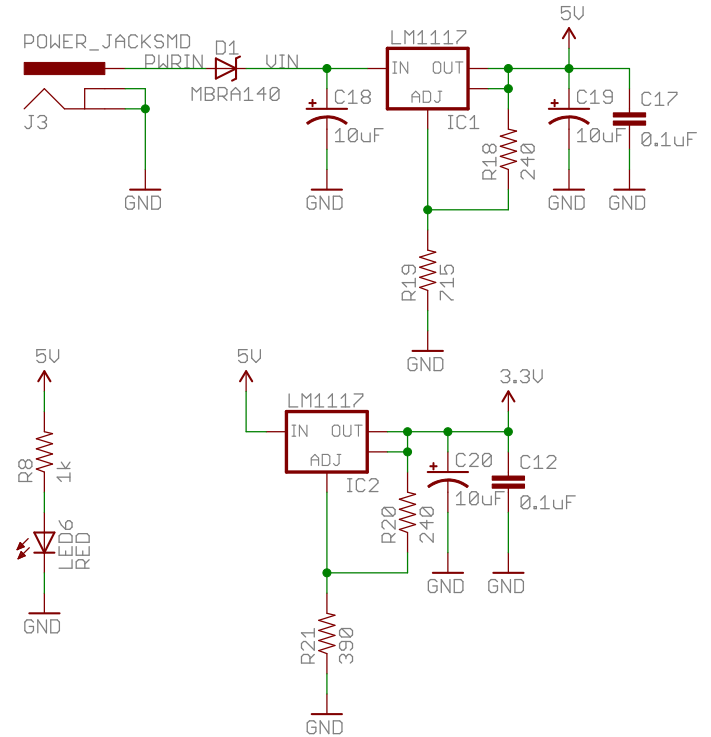

# Programming

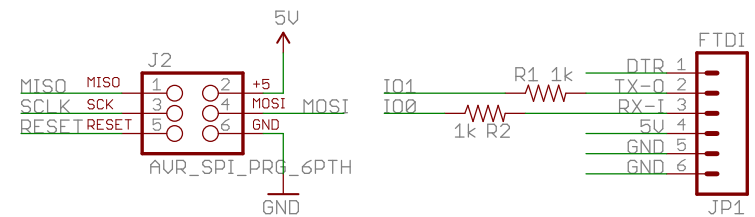

TITLE: Arduino-Ethernet-v11

SFE SFE

Document Number:

REV:

Date: 3/31/2011 6:50:54 AM

Sheet: 1/2

W5100

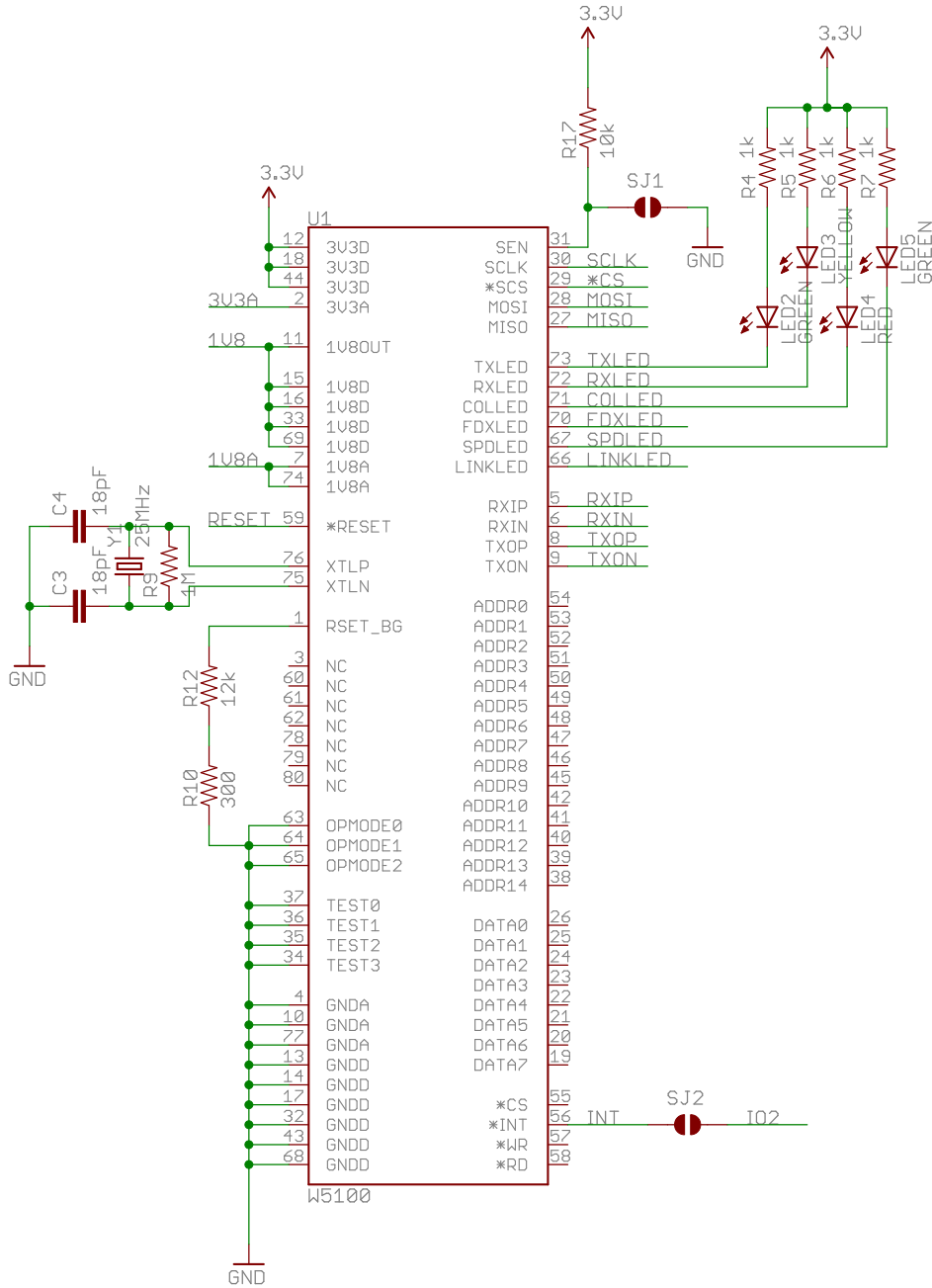

MAGJACK

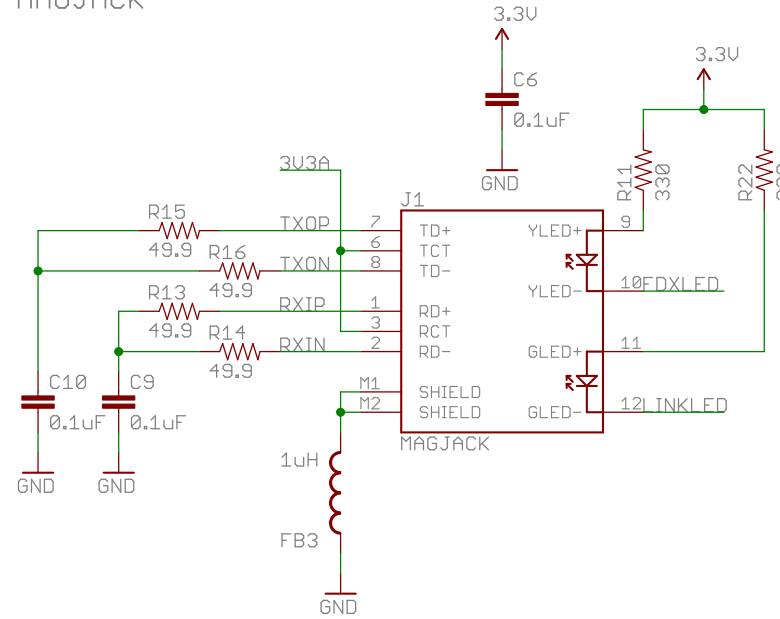

DECOUPLING

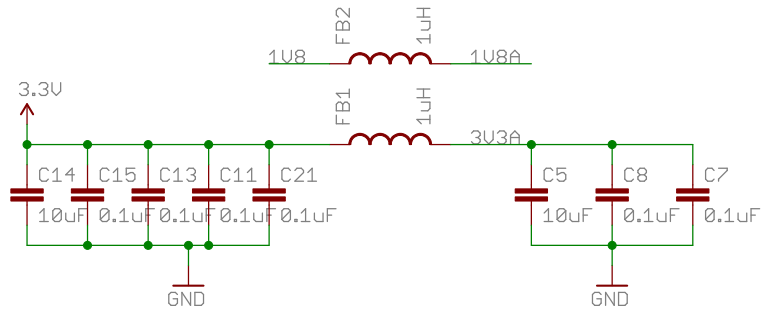

TITLE: Arduino-Ethernet-v11 SFE

Document Number: REV:

Date: 3/31/2011 6:50:54 AM Sheet: 2/2